

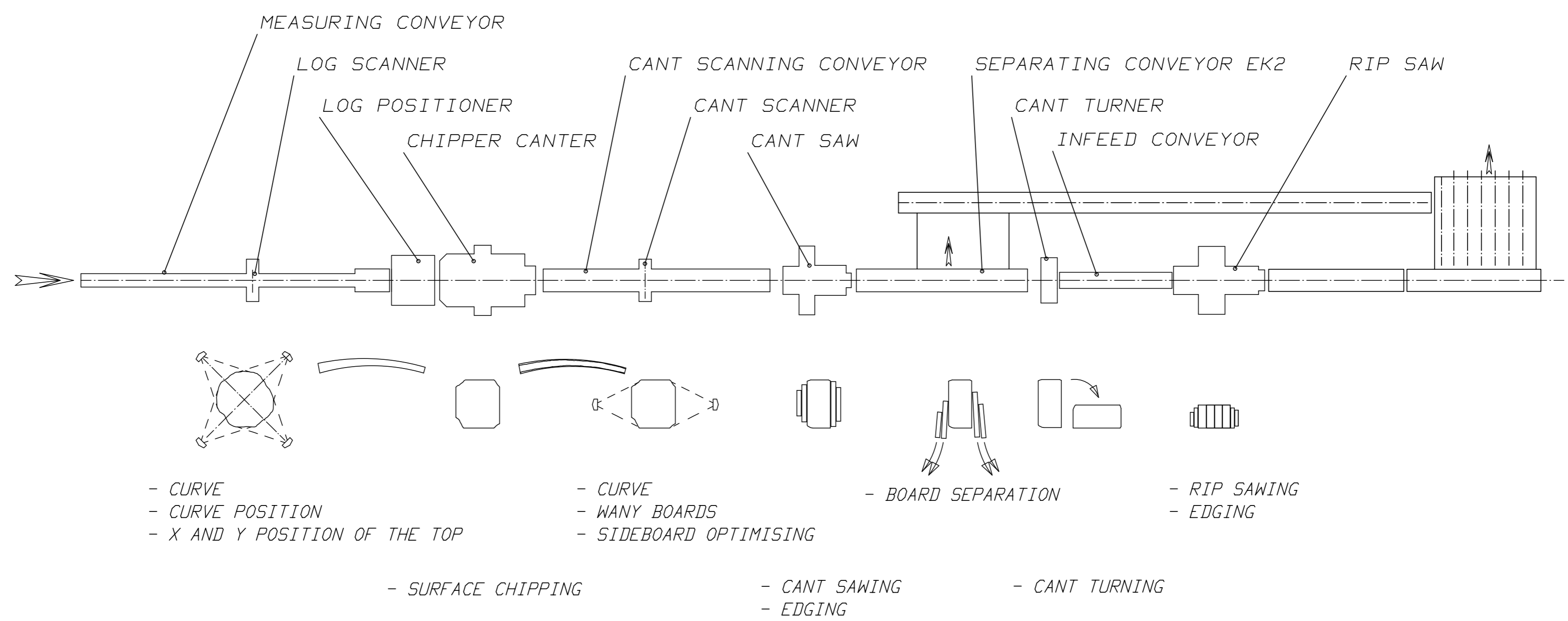

\*HewSaw® is a trademark of VEISTO OY.  
 \*Käyttöoikeus on VEISTO OY:n omaisuus. Kukaan ei saa kopioida, jäljentää tai käyttää tätä asiakirjaa ilman VEISTO OY:n kirjallista lupaa.  
 \*All rights reserved. This document is the property of VEISTO OY. No part of it may be reproduced, stored in a retrieval system, or transmitted in any form or by any means, electronic, mechanical, photocopying, recording, or by any information storage and retrieval system, without the prior written permission of VEISTO OY.  
 \*Tämä asiakirja on VEISTO OY:n omaisuus. Kukaan ei saa kopioida, jäljentää tai käyttää tätä asiakirjaa ilman VEISTO OY:n kirjallista lupaa.  
 \*All rights reserved. This document is the property of VEISTO OY. No part of it may be reproduced, stored in a retrieval system, or transmitted in any form or by any means, electronic, mechanical, photocopying, recording, or by any information storage and retrieval system, without the prior written permission of VEISTO OY.

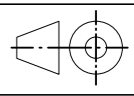

**HewSaw®**  
**VEISTO GROUP**  
**VEISTO OY**

**SL250**  
**TRIO**

Scale:	Dr. PL	2005-06-02	Repl./Rep Id:		Weight:
	App.		Ref.		From: H654800
 VEISTO GROUP VEISTO OY	SAWING LINE SL250 TRIO			J647200 DOKUMENTTI	
	OPERATIONAL LAYOUT			Job n:o	
				Dwg n:o J647200	